

# TELEPHONE HEADSET SYSTEM

## S12



### QUICK START USER GUIDE

## WELCOME

The S12 Telephone Headset System is designed to add a headset to an existing telephone.

The S12 System provides precise levels of listening and talking comfort and crystal clear voice quality.

The S12 System is not designed to work on telephones that have the dial pad in the handset or on cordless telephones.

This user guide provides the following steps to quickly set up and use your headset system.

1. Identify the Components
2. Attach to Telephone
3. Set Amplifier Compatibility Switch
4. Make a Test Call

The other side has more details:

- Examine other features
- Troubleshooting
- Technical Support Center Information
- FCC Information
- Parts and Accessories
- Warranty and Service

## IMPORTANT SAFETY INSTRUCTION

Read and follow all instructions and warnings prior to using the product.

When using your telephone equipment, basic safety precautions should always be followed to reduce the risk of fire, electric shock and injury to persons, including the following:

### WARNINGS

For your comfort, health, and safety, do not exceed moderate listening levels.

Use only the Listed AC power adapter supplied by Plantronics.

Unplug this product from the wall outlet before cleaning. Do not use liquid cleaners or aerosol cleaners.

Avoid contact with liquids. Do not locate this product near water, for example, near a bath-tub or sink, in a wet basement, or near a swimming pool.

This product should never be placed near or over a radiator or heat register. This product should not be placed in a built-in installation unless proper ventilation is provided.

Do not allow anything to rest on the power cord. Do not locate this product near operating machinery or in areas where the power cord is likely to be damaged by furniture or foot traffic.

Discontinue use of product and contact Plantronics if the product overheats, has a damaged cord or plug, has been dropped or damaged, or if the product has been dropped in water.

Do not overload outlets and extension cords as this can result in the risk of fire or electric shock.

Never disassemble or push objects of any kind into this product as this may short out parts that could result in a fire or electric shock.

Use caution when installing or modifying telephone lines.

Do not use the telephone equipment to report a gas leak in the vicinity of the leak.

Avoid using a telephone (other than a cordless type) during an electrical storm. There may be a remote risk of electric shock from lightning.

Use only with class 2 Power source: Plantronics Part No.: 45671-01, rated at an Input Voltage of 100-240VAC, 50/60Hz, 0.2A and Output Voltage of 9VDC, 500mA.

### SAVE THESE INSTRUCTIONS

## S12 QUICK START GUIDE

### 1 Identify the Components

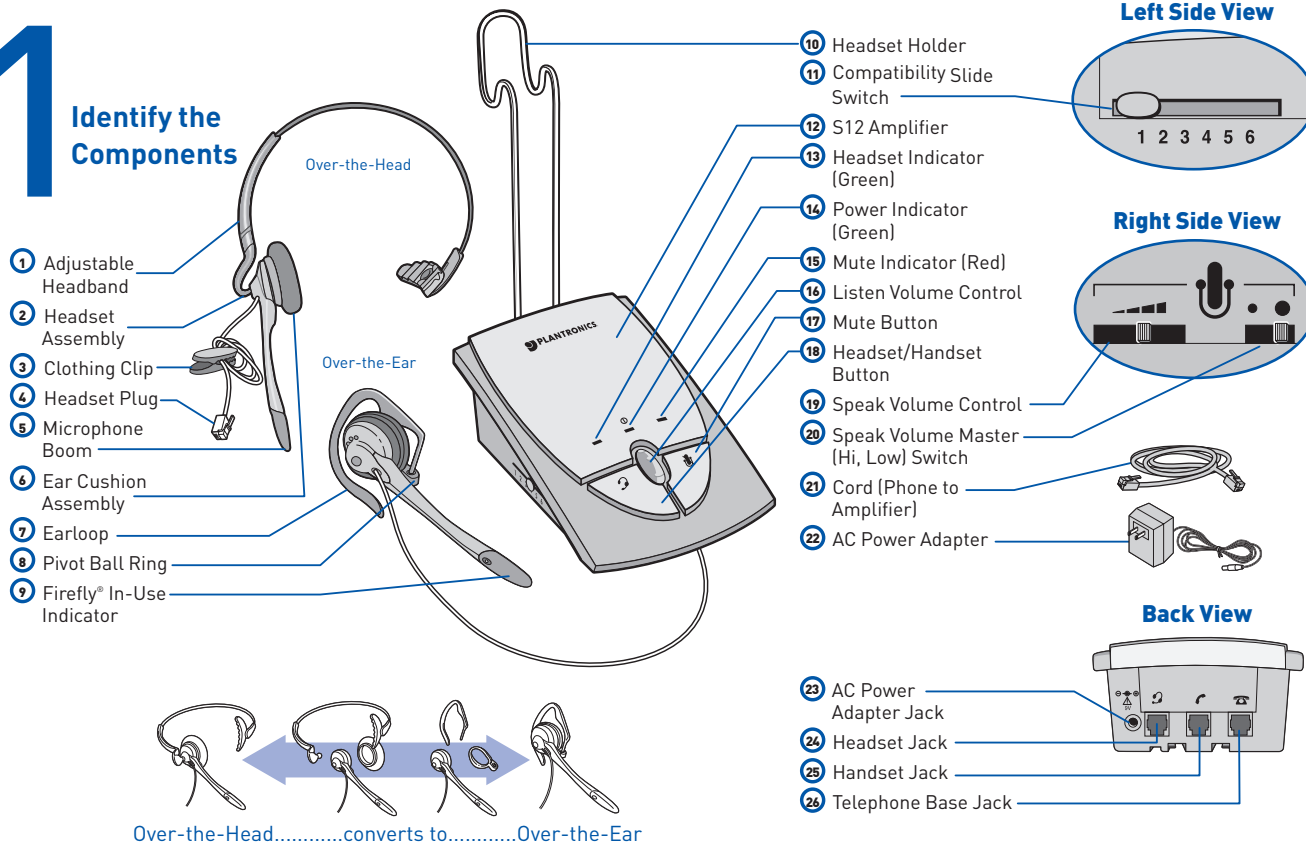

### 2 Attach Amplifier to Telephone

**2.1** Unplug your telephone handset cord from the telephone base.

**2.2** Plug your telephone handset cord into the S12 amplifier handset jack.

**2.3** Connect the cord between the telephone base jack on the S12 amplifier and your telephone base.

**2.4** Plug the headset plug into the headset jack.

**2.5** Route the headset cord through the cable management channel on the bottom of the amplifier (not shown).

**2.6** Snap in the headset holder (not shown).

**2.7** Plug the AC power adapter into the AC power adapter jack and plug into a standard AC wall output.

### 3 Set Amplifier Compatibility Slide Switch

**3.1** Put on headset and press the headset button.

The headset indicator should be on (green).

**3.2** Lift the telephone's handset off the cradle and place it on your desk.

**3.3** If you hear a clear dial tone, you can proceed to Step 4.

**3.4** If you don't hear a dial tone, adjust the compatibility slide switch following this process:

1. Slide the compatibility slide switch until you hear a clear dial tone.

There may be multiple settings with a dial tone. Select the one that sounds most like the handset of your phone.

Experimenting with various switch settings will not harm the amplifier or your telephone.

### 4 Make a Test Call

**4.1** Verify that the mute button is off.

The mute indicator should not be illuminated

**4.2** Remove the phone handset from the cradle and place on your desk.

1. If you do not hear a dial tone in the headset, press the headset button.

The headset indicator is on.

**4.3** Use your telephone keypad to call a friend or colleague.

**4.4** Adjust the listen volume using the listen volume control. Volume setting on the phone should be fixed at a nominal setting.

**4.5** If your friend cannot hear you, or you hear a buzz or hum, try changing the compatibility slide switch.

**4.6** Adjust how loud you sound to the other party by adjusting the speak volume control.

**4.7** If you sound too loud, move the speak volume master switch to its lower setting and adjust the speak volume control.

**4.8** After completing the call, return the handset to its cradle.

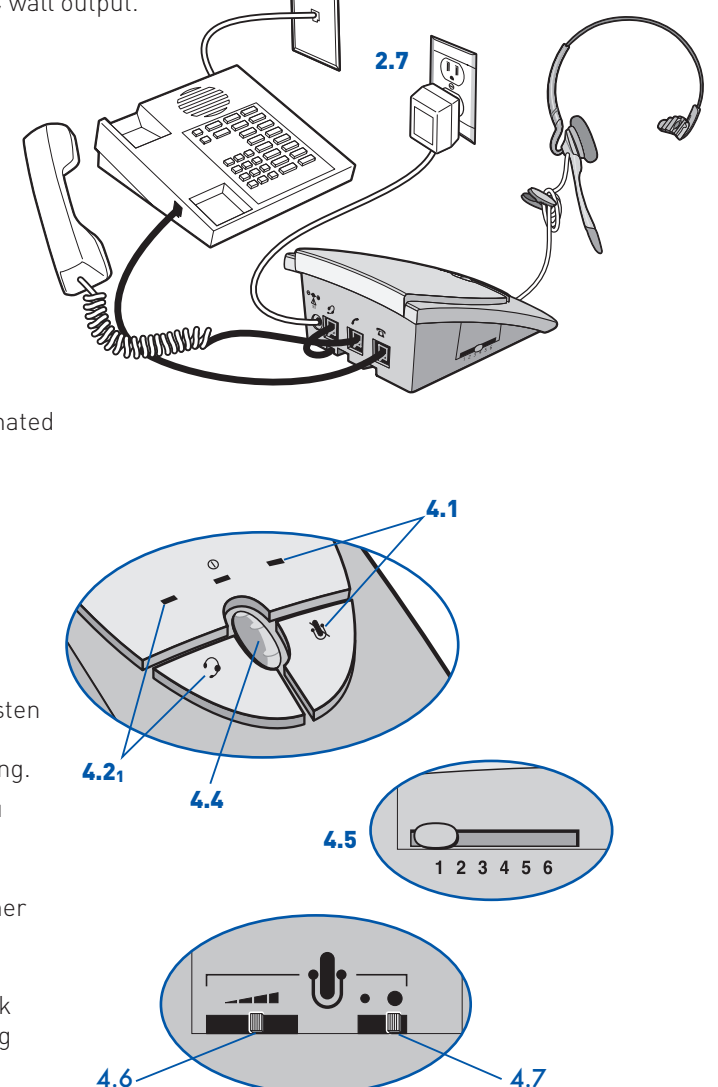

# EXAMINE OTHER FEATURES

## 1 To receive calls with your headset

- 1.1 Put on your headset.
- 1.2 When your telephone rings, push the headset button. The headset indicator  should be on (green).
- 1.3 Remove the handset from the cradle and place it on your desk.
- 1.4 Begin talking to your calling party.
- 1.5 When you are finished, hang up the handset.

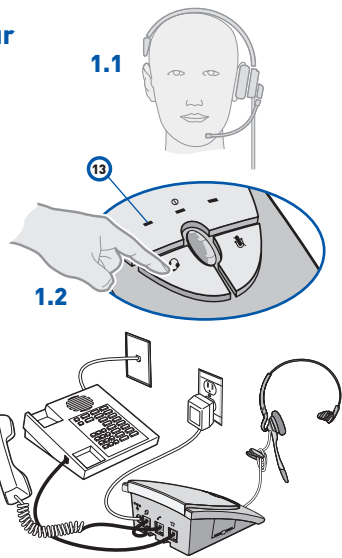

## 2 To use your telephone handset

- 2.1 Push the headset button. The headset indicator should not be illuminated.
- 2.2 Use the telephone handset as normal.

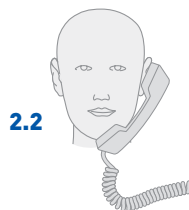

## 3 To switch from your telephone handset to your headset

- 3.1 Alert your caller that there will be a short delay, and put on your headset.
- 3.2 Push the headset button. The headset indicator should be on (green).
- 3.3 Resume talking through your headset.

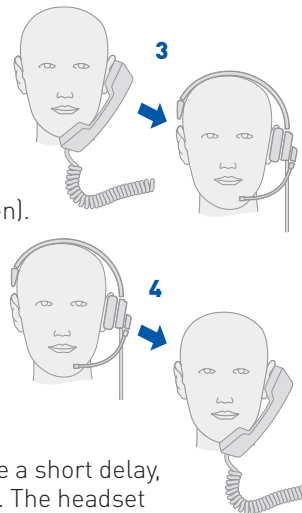

## TIP: The handset must remain off the cradle during phone calls.

## 4 To switch from your headset to your telephone handset

- 4.1 Alert your caller that there will be a short delay, and then release the headset button. The headset indicator should not be illuminated.
- 4.2 Remove your headset and pick up your handset.
- 4.3 Resume talking through your telephone handset.

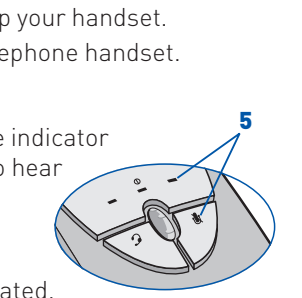

## 5 To use the mute function.

- 5.1 Press the mute button. The mute indicator should be on (red). You will be able to hear them but they can not hear you.
- 5.2 Release the mute button to deactivate the mute function. The mute indicator should not be illuminated.

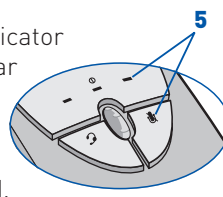

## Your working system should look like this:

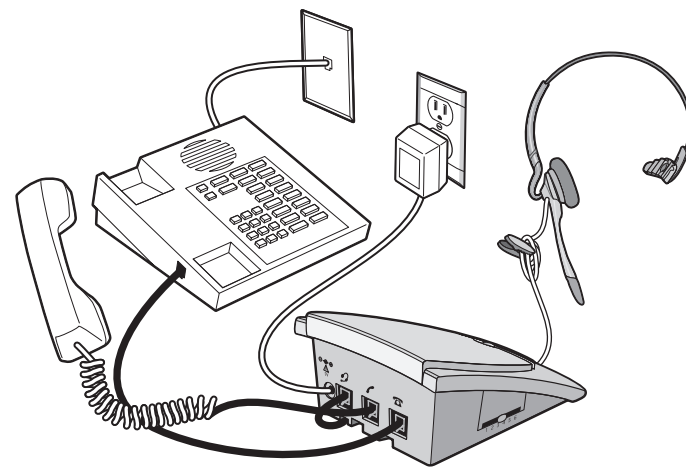

It provides the following benefits:

- SoundGuard® Plus™ technology quickly reduces the level of harsh noises, such as fax tones
- Call Clarity™ improves incoming and outgoing sound
- Switch easily with one button selection between headset and handset
- Incoming and outgoing volume control
- Mute control

## TROUBLESHOOTING

### I cannot hear a dial tone.

- Make sure all cable connections are correct and firmly in place.
- Pay special attention that handset cord  is properly connected.
- Ensure AC power adapter is connected and power is on.
- Make sure you have pressed the headset button and the headset indicator is on.
- Make sure the telephone handset is off-hook.
- Adjust listen volume control.
- Adjust the compatibility slide switch.
- Ensure that the headset is centered on your ear.

### Caller cannot hear my voice.

- Make sure the mute button is turned off (indicator off).
- Increase the outgoing volume by adjusting the speak volume control
- Adjust headset so the microphone is closer to your mouth.

### I hear a hum in the headset.

- Adjust the compatibility slide switch until the sound is clear. Trying other settings will not harm the amplifier or your telephone.

### Plantronics Help Desk

The Plantronics Help Desk is ready to assist you! Dial 1-800-544-4660 or visit our website at [plantronics.com](http://plantronics.com).

## FCC REQUIREMENTS

### Part 68

This equipment complies with Part 68 of the FCC rules and the requirements adopted by the ACTA. On this equipment is a label that contains, among other information, a product identifier in the format US:AAAEQ##TXXXX. If requested, this number must be provided to the telephone company.

A plug and jack used to connect this equipment to the premises wiring and telephone network must comply with the applicable FCC Part 68 rules and requirements adopted by the ACTA. A compliant telephone cord and modular plug is provided with this product. It is designed to be connected to a compatible modular jack that is also compliant. See installation instructions for details.

The REN is used to determine the number of devices that may be connected to a telephone line. Excessive RENs on a telephone line may result in the devices not ringing in response to an incoming call. In most but not all areas, the sum of RENs should not exceed five (5.0). To be certain of the number of devices that may be connected to a line, as determined by the total RENs, contact the local telephone company. For products approved after July 23, 2001, the REN for this product is part of the product identifier that has the format US: AAAEQ##TXXXX. The digits represented by ## are the REN without the decimal point (e.g., 03 is an REN of 0.3). For earlier products, the REN is separately shown on the label.

If this equipment causes harm to the telephone network, the telephone company will notify you in advance that temporary discontinuance of service may be required. But if advance notice isn't practical, the telephone company will notify the customer as soon as possible. Also, you will be advised of your right to file a complaint with the FCC if you believe it is necessary.

The telephone company may make changes in its facilities, equipment, operations or procedures that could affect the operation of the equipment. If this happens the telephone company will provide advance notice in order for you to make the necessary modifications to maintain uninterrupted service.

If trouble is experienced with this equipment, for repair or warranty information, please contact Plantronics, Inc. 345 Encinal Street, Santa Cruz, CA 95060 (800-544-4660). If the equipment is causing harm to the telephone network, the telephone company may request that you disconnect the equipment until the problem is resolved.

Connection to party line service is subject to state tariffs. Contact the state public utility commissions, public service commission or corporations commission for information. If your home has specially wired alarm equipment connected to the telephone line, ensure the installation of this equipment does not disable your alarm equipment. If you have questions about what will disable alarm equipment, consult your telephone company or a qualified installer.

**DO NOT DISASSEMBLE THIS EQUIPMENT.** It does not contain any user serviceable components.

We recommend the installation of an AC surge arrester in the AC outlet to which this equipment is connected. Telephone companies report that electrical surges, typically lightning transients, are very destructive to customer terminal equipment connected to AC power sources.

### FCC Requirements—Part 15

This device complies with Part 15 of the FCC Rules. Operation is subject to the following two conditions:

1. This device may not cause harmful interference, and
2. This device must accept any interference received, including interference that may cause undesired operation.

### WARNING:

Changes or modifications to this unit not expressly approved by the party responsible for compliance could void the user's authority to operate the equipment.

This equipment has been tested and found to comply with the limits for a Class B digital device, pursuant to Part 15 of the FCC Rules. These limits are designed to provide reasonable protection against harmful interference in a residential installation. This equipment generates, uses, and can radiate radio frequency energy and, if not installed and used in accordance with the instructions, may cause harmful interference to radio communications.

However, there is no guarantee that interference will not occur in a particular installation. If this equipment does cause harmful interference to radio or television reception which can be determined by turning the radio or television off and on, the user is encouraged to try to correct interference by one or more of the following measures:

1. Reorient or relocate the receiving antenna.
2. Increase the separation between the equipment and receiver.
3. Connect the equipment into an outlet on another circuit.
4. Consult the dealer or an experienced radio/TV technician for help.

## INDUSTRY CANADA NOTICE

This Class B digital apparatus complies with Canada ICES003.

### Terminal Equipment

**Notice:** This equipment meets the applicable Industry Canada Terminal Equipment Technical Specifications. This is confirmed by the registration number. The abbreviation, IC, before the registration number signifies that registration was performed based on a Declaration of Conformity indicating that Industry Canada technical specifications were met. It does not imply that Industry Canada approved the equipment.

**Notice:** The Ringer Equivalence Number (REN) for this terminal equipment is marked on the equipment itself. The REN assigned to each terminal equipment provides an indication of the maximum number of terminals allowed to be connected to a telephone interface. The termination on an interface may consist of any combination of devices subject only to the requirement that the sum of the Ringer Equivalence Numbers of all the devices does not exceed five.

## LIMITED WARRANTY

for Plantronics Commercial Products Purchased in the US and Canada

- This warranty covers defects in materials and workmanship of Commercial Products manufactured, sold or certified by Plantronics which were purchased and used in the United States and Canada.
- This warranty lasts for one year from the date of purchase of the Products.
- This warranty extends to you only if you are the end user with the original purchase receipt.
- We will, at our option, repair or replace the Products that do not conform to the warranty. We may use functionally equivalent reconditioned/refurbished/remanufactured/pre-owned or new Products or parts.
- To obtain service in the U.S. contact Plantronics at (800) 544-4660 and in Canada call (800) 540-8363. If you need additional information, please contact our service centers at the numbers provided.
- THIS IS PLANTRONICS' COMPLETE WARRANTY FOR THE PRODUCTS.
- This warranty gives you specific legal rights, and you may also have other rights which vary from state to state or province to province. Please contact your dealer or our service center for the full details of our limited warranty, including items not covered by this limited warranty.



World Leader in Communications Headsets

345 Encinal Street  
Santa Cruz, California 95060  
(800) 544-4660

[www.plantronics.com](http://www.plantronics.com)

© 2002-2016 Plantronics, Inc. All rights reserved. Plantronics, the logo design, Plantronics and logo design combined, Call Clarity, Firefly and SoundGuard Plus are trademarks or registered trademarks of Plantronics, Inc. All other trademarks are the property of the respective owners.

Patents U.S. 5,210,791, D394,437 & D403,327; Finland 20183 & 20184; GB Regd.Des.No. 2073246 & 2073247; Sweden 64 176 & 64 177

## PARTS

